

LONG HANDLE TRUCK AND TRAILER TWIST LOCK

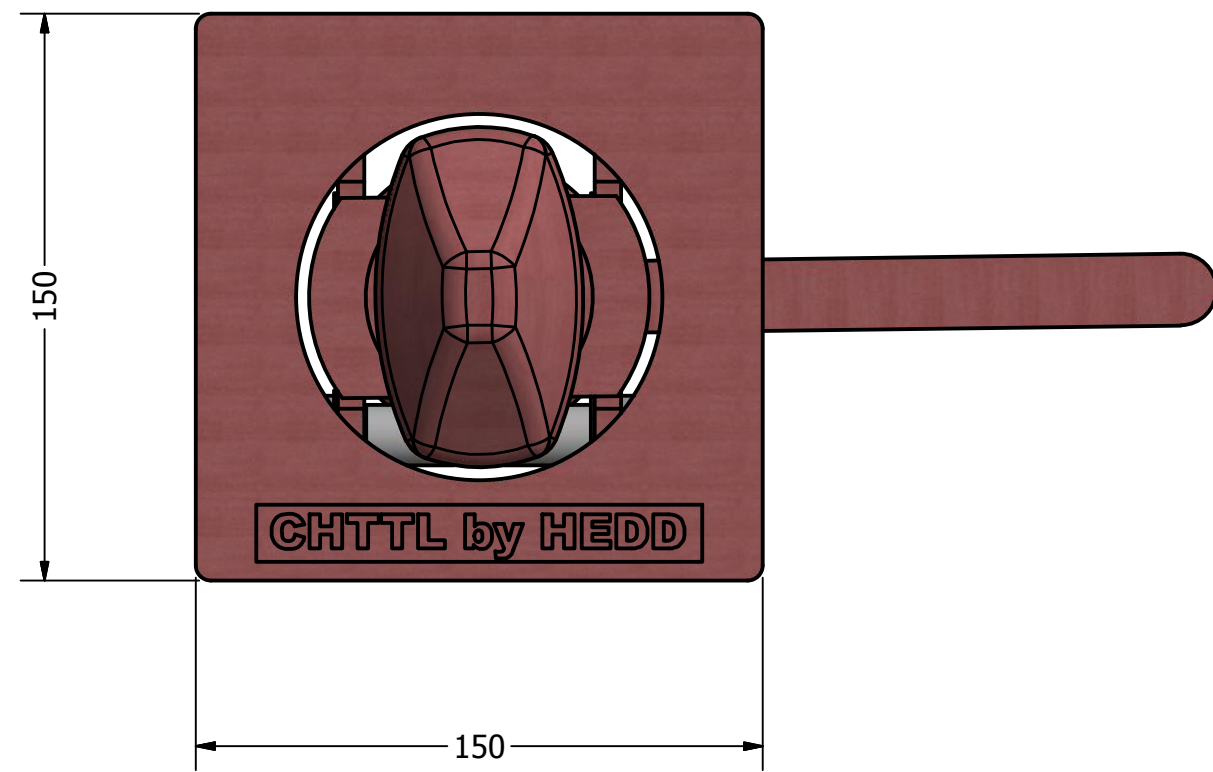

SWL Tension: 250 kN
 SWL Shear: 210 kN
 MBL Tension: 500 kN
 MBL Shear: 420 kN

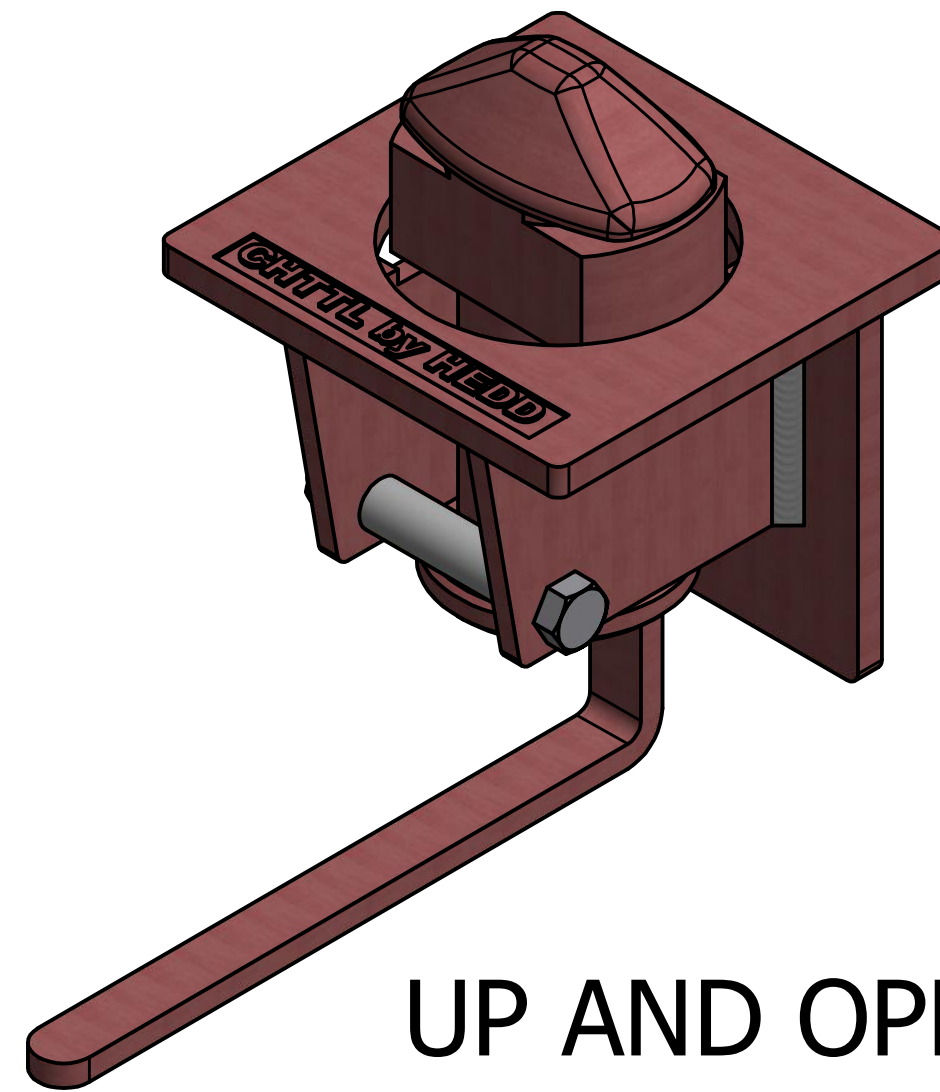
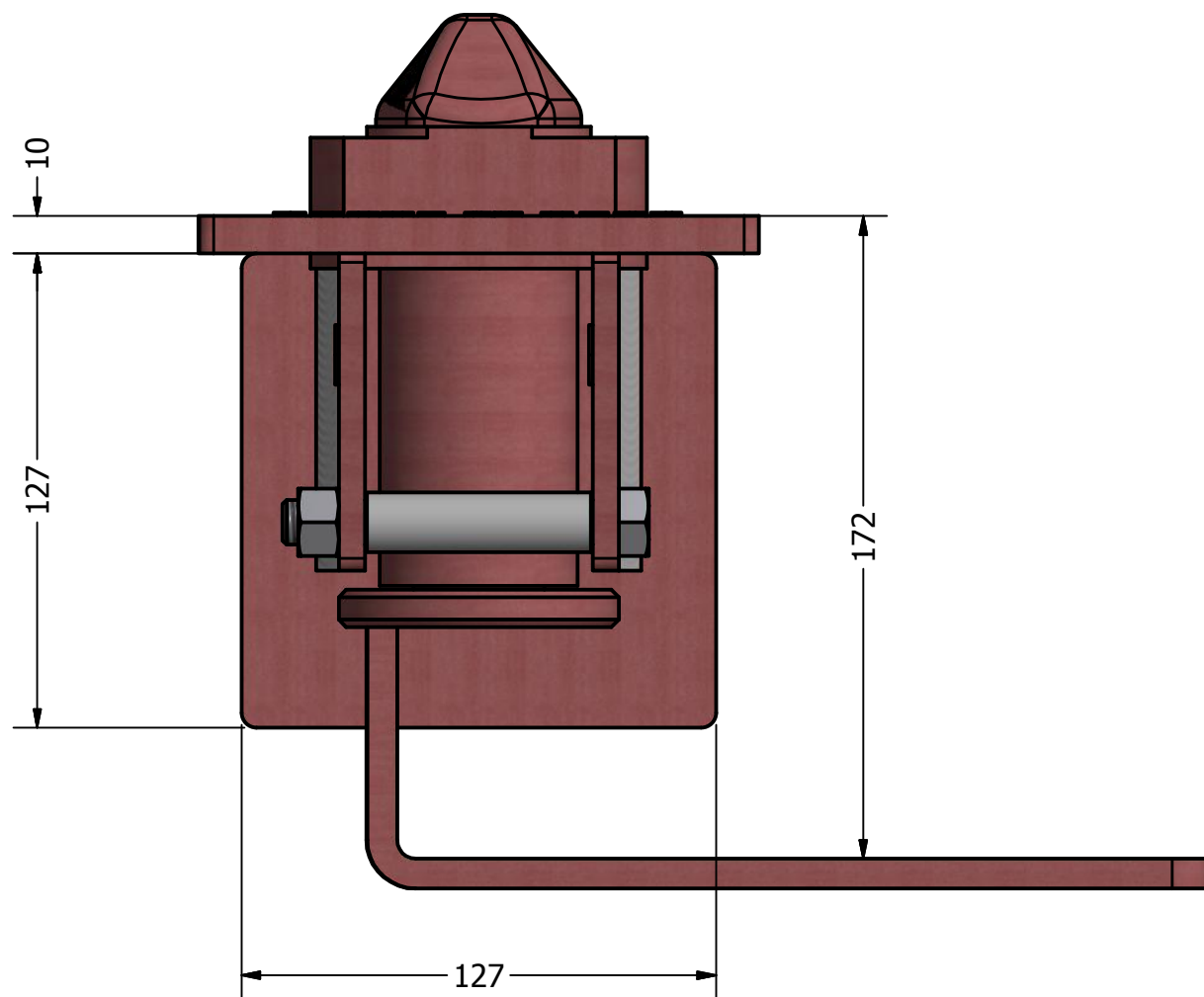

UP AND CLOSED

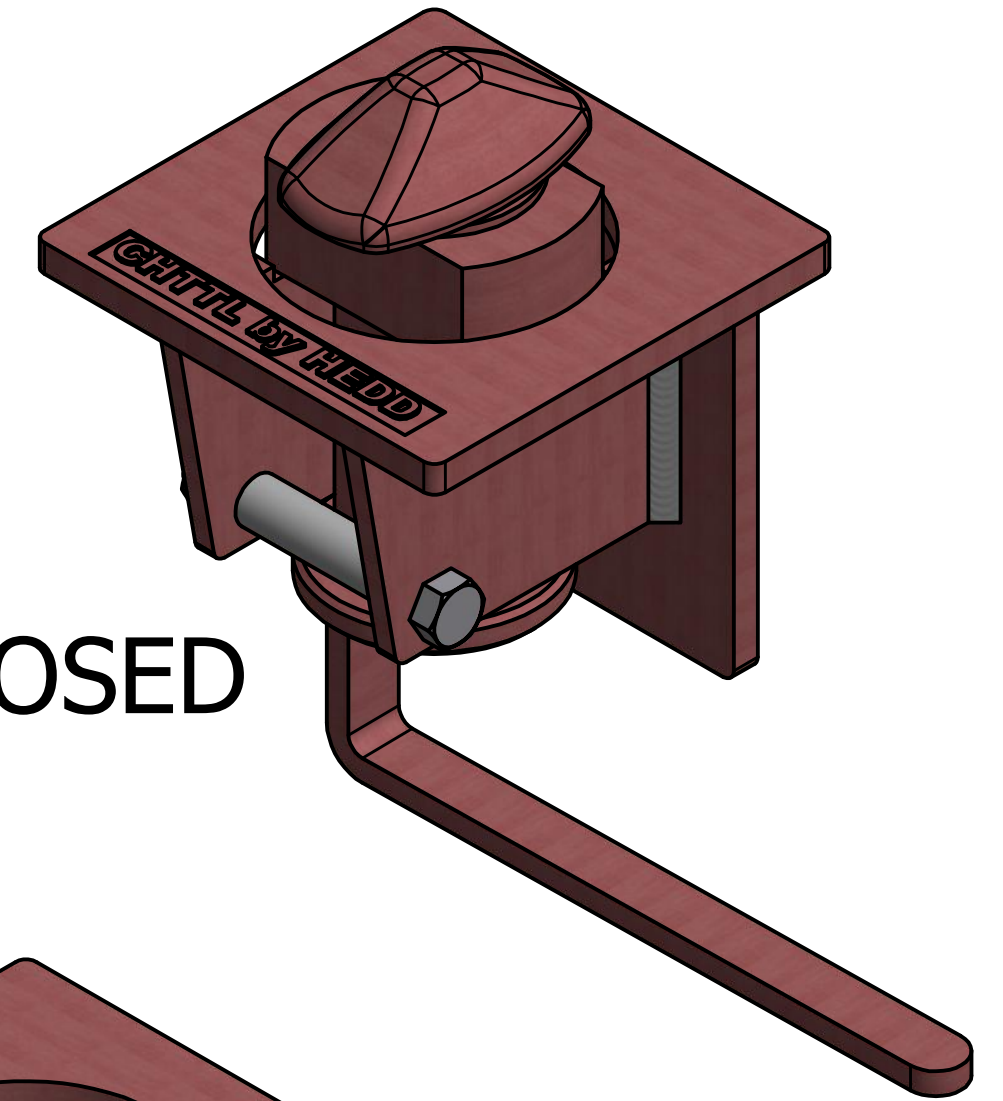

UP AND OPEN

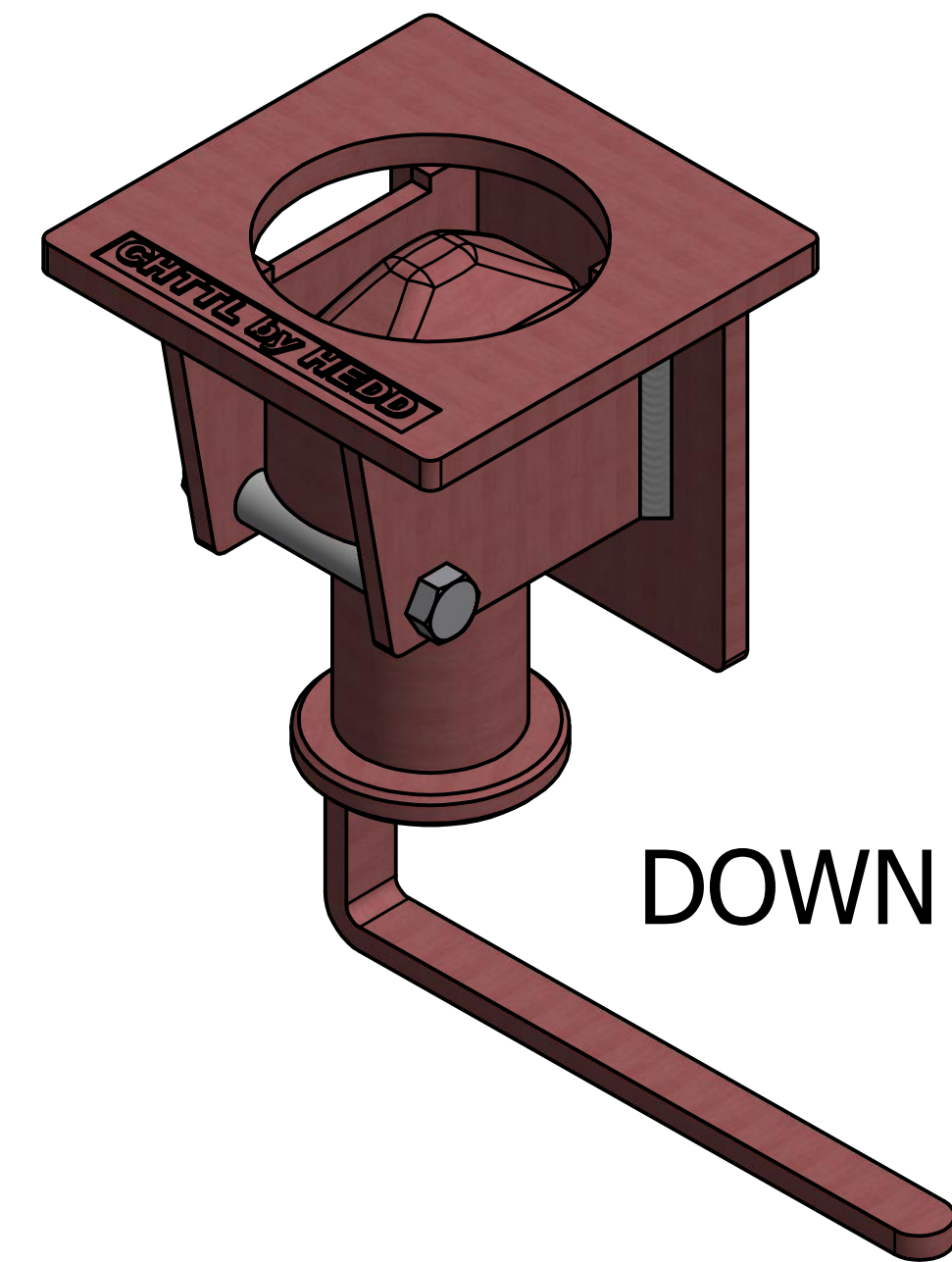
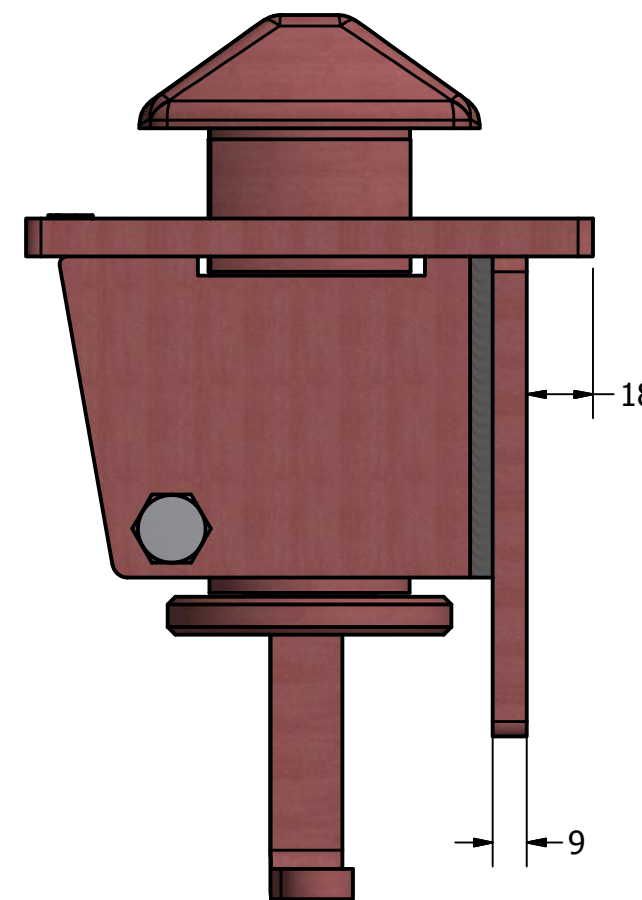

DOWN

PHONE: 0425 276 837

DRAWN	4/12/2012	CONTAINER HOARDINGS		
User		TITLE		
CHECKED		TRUCK AND TRAILER TWIST LOCK Long Handle		
QA		SIZE	DWG NO	REV
MFG		A2	Part Number CHTTL-LH	01
APPROVED		SCALE	SHEET 1 OF 1	